

Austview Sashless Single Slide Bottom Fixed or Top Fixed

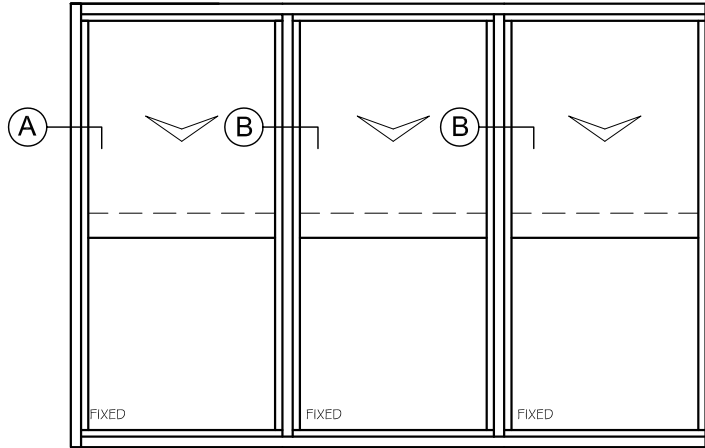

Typical Elevation - Drawing Reference

Scale N.T.S



STANDARD JAMB/MULLION DETAIL

NOTE: Either bottom or top panel can be fixed

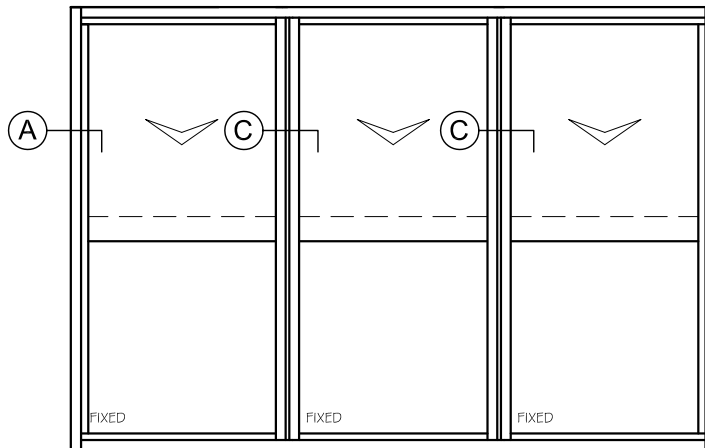

OPTIONAL MULLION DETAIL

NOTE: Either bottom or top panel can be fixed

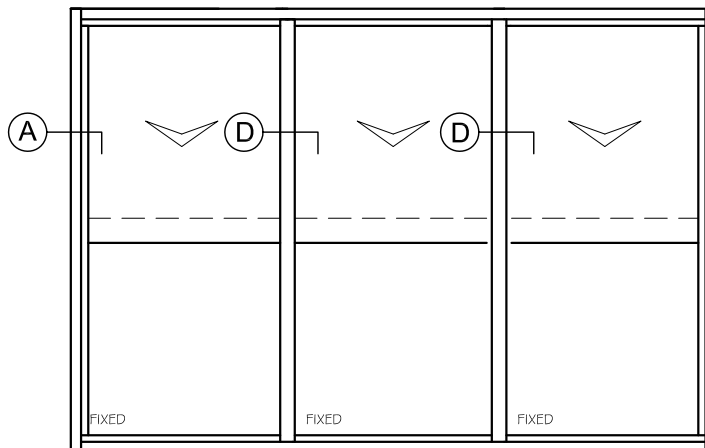

OPTIONAL MULLION DETAIL

NOTE: Either bottom or top panel can be fixed

Austview Sashless Single Slide Bottom Fixed or Top Fixed



Jamb and Mullion

Scale 1:2

A) JAMB DETAIL

ALUMINIUM WEIGHT BOX SIZE
VARY DUE TO COUNTER WEIGHT
SIZE REQUIRED

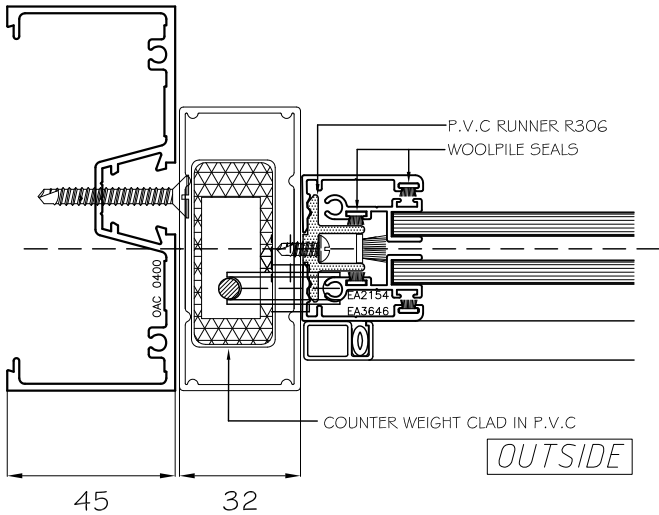

B) MULLION DETAIL

ALUMINIUM WEIGHT BOX SIZE
VARY DUE TO COUNTER WEIGHT
SIZE REQUIRED

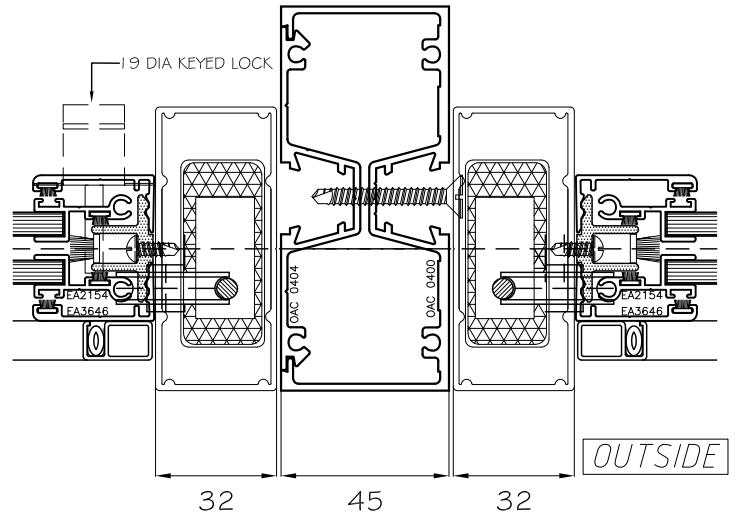

C) OPTIONAL MULLION DETAIL

ALUMINIUM WEIGHT BOX SIZE
VARY DUE TO COUNTER WEIGHT
SIZE REQUIRED

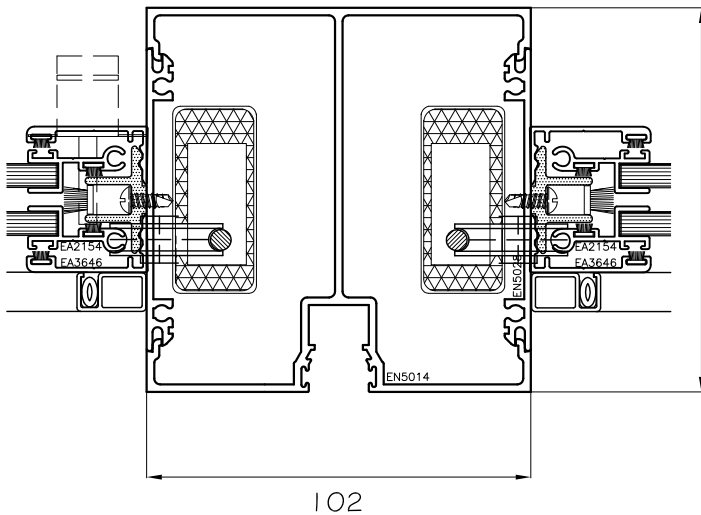

D) OPTIONAL MULLION DETAIL

ALUMINIUM WEIGHT BOX SIZE
VARY DUE TO COUNTER WEIGHT
SIZE REQUIRED

