

3 PANEL AUSTVIEW SASHLESS TIMBER WINDOW,  
FIXED TO TIMBER FRAME

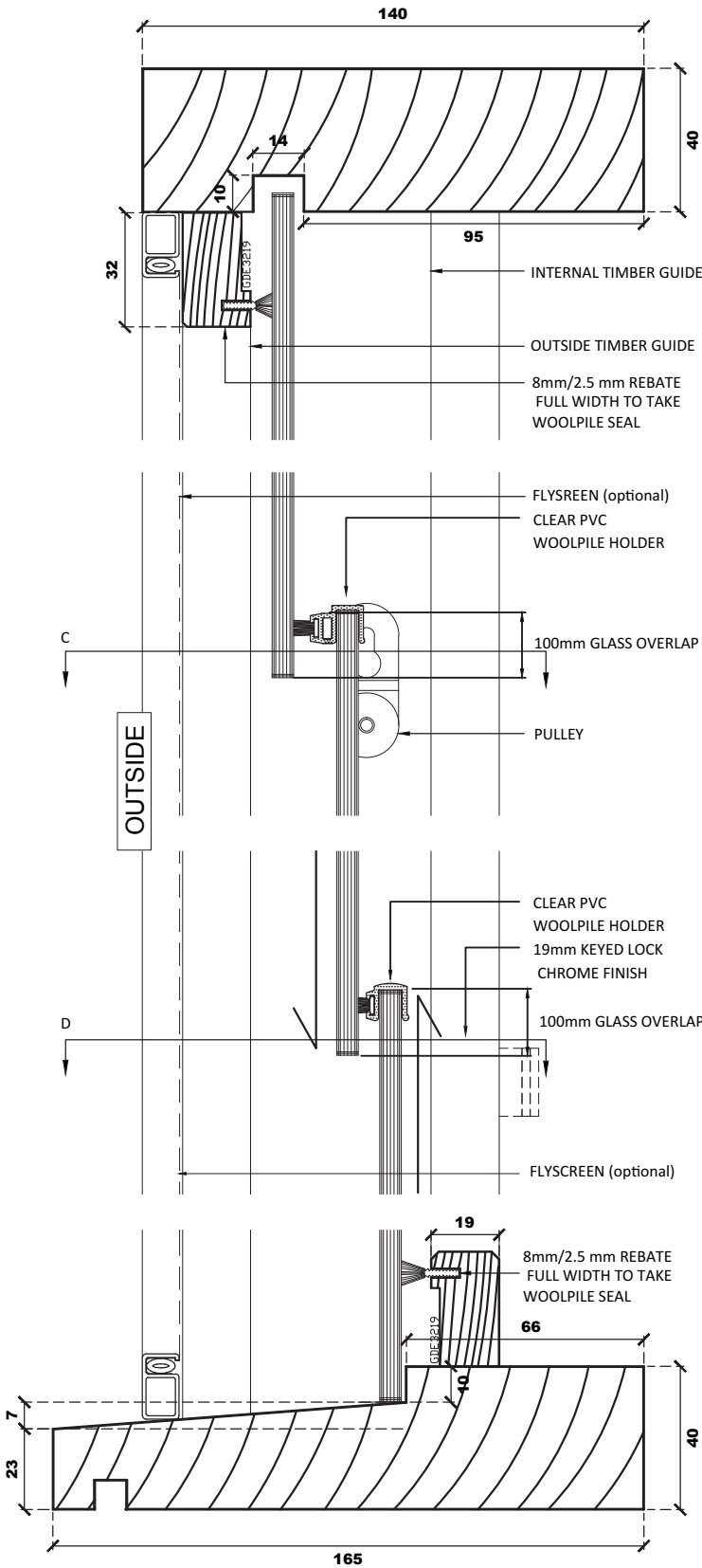

HEAD, SILL AND JAMB



DETAIL (A)  
**Head Detail**

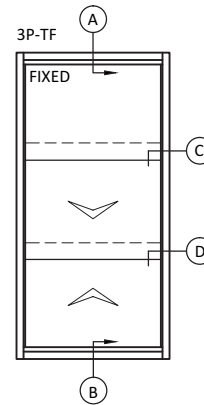

DETAIL (C)  
**Jamb Detail**

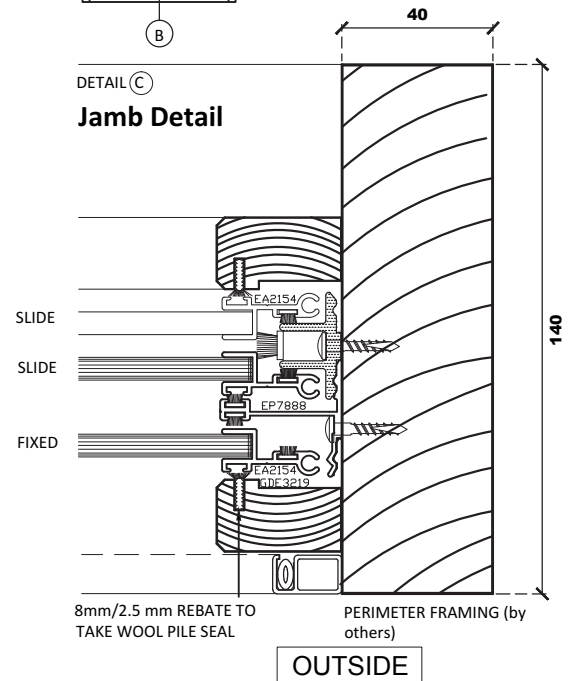

DETAIL (D)  
**Jamb Detail**

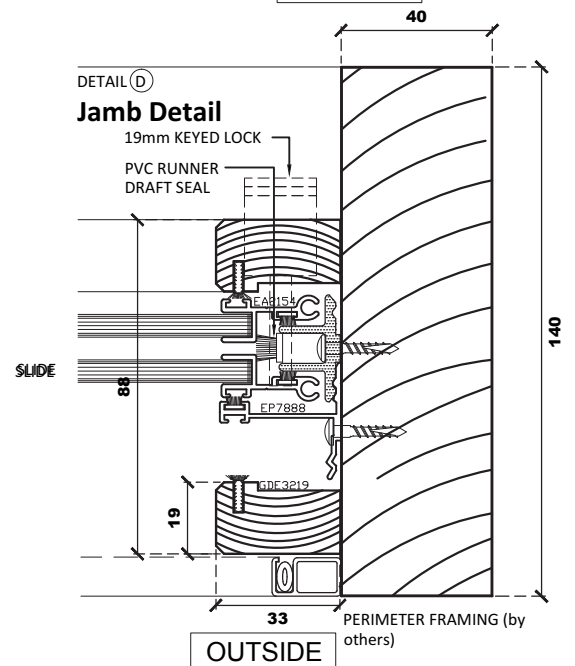

Australian Standard 2047