

IAN BENNIE AND ASSOCIATES

**TEST REPORT NO. 20206S5
TIMBER SASHLESS DOUBLE HUNG
WINDOW
PROTOTYPE TEST to AS2047-1999**

**for
Austview**

June 2002



Registered Laboratory No. 2371



WINDOW TEST NUMBER 20206S5

Test Client: Austview

Sample

Identification: A Timber Sashless Double Hung Window, measuring, 2100 mm in height x 900 mm in width. The sample is detailed in the Austview drawings given in Appendix B.

Test Method: Operating Force, Air Infiltration, Water Penetration Resistance and Ultimate Strength test performance requirements to Clause 2.3 of Australian Standard AS2047-1999, and test procedures to Australian Standard AS4420-1996 as detailed in Appendix A.

Test Location: IBA Test Centre
Dandenong, Melbourne.

Test Date(s): 20 June 2002.

Drawing(s) Received: 20 June 2002

Pre-loading: The sample was operated five times and preloaded prior to commencement of testing.

TEST RESULTS

Deflection Test

No deflection test was required as the sample did not include any structural framing members.

Operating Force Test

Force (Newton)	Requirement	Force Measured
To initiate movement	200 maximum	Opening: 105 Closing : 96
To maintain movement	160 maximum	Opening: 91 Closing : 97

Air Infiltration Test

Air Leakage Recorded (L/s.m ²)	Pressure Applied (Pa)			
	+75	+150	-75	-150
Condition				
Chamber & Sample (A):	1.69	2.61	-1.70	-2.61
Chamber (sample taped) (B):	NR	NR	NR	NR
Sample (A-B):	1.69	2.61	-1.70	-2.61

NR: measurement not required

Water Penetration Test, 250 Pa

Water was observed in one (1) location during the test.

- 1/ Water appeared on the sill pile seal and remained there until the end of the test when it drained out. This leak does not constitute failure.

Ultimate Strength Test: +2300 Pa & -2300 Pa

No sign of collapse was observed at +2300 Pa and -2300 Pa.

CONCLUSION

The Timber Sashless Double Hung Window sample achieved the following ratings per AS2047-1999 when tested for Operating Force, Air Infiltration, Water Penetration Resistance and Ultimate Strength. Building classifications and housing limitations are summarised in Appendix A and Regions are as per AS1170.2.

Housing ratings:

Regions A & B..... N4 #
Region C.....+833 ‡and -920 # Pa
Region D+793 #and -793 # Pa

Residential building ratings:

Region A+833 ‡and ...-1329 # Pa
Regions B & C.....+833 ‡and -920 # Pa
Region D+793 #and -793 # Pa

Commercial building ratings:

Region A+833 ‡and ...-1329 # Pa
Regions B & C.....+833 ‡and -920 # Pa
Region D+793 #and -793 # Pa

‡ - rating is limited by the maximum water test pressure applied without failure.

- rating is limited by the maximum ultimate test pressures applied without failure.

Air Infiltration: Non-airconditioned Buildings only

Maximum Water Penetration Resistance pressure: 250 Pa

DISTRIBUTION:

Ian Bennie & Associates 3
Austview..... 2

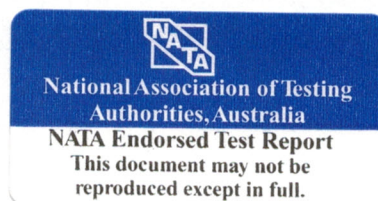

.....
Derek Dubout 26 June 2002
Authorised NATA Signatory

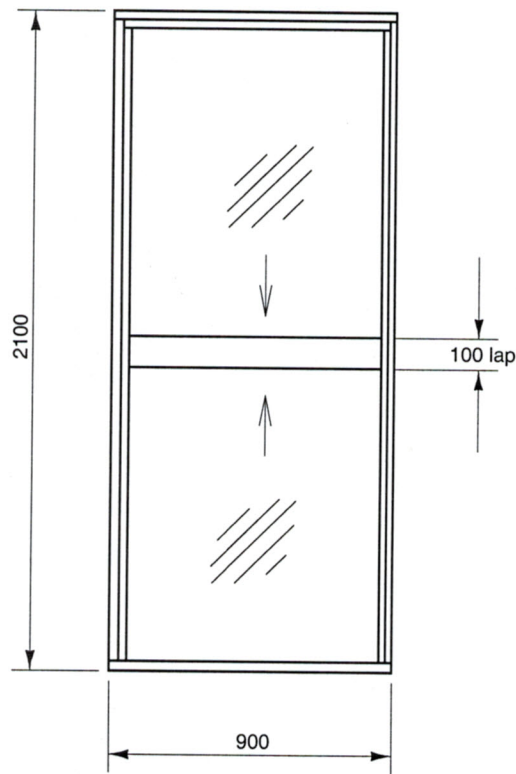

Figure 1. Indoor view of the test sample.

APPENDIX A - TEST PROCEDURES FOR AS2047-1999/ Amdt 1 & Amdt 2

0 Definitions

Please refer to AS2047-1999, Amdt 1, Amdt 2, AS4055-1992 and the Building Code of Australia for full details.

Housing: AS2047-1999 Clause 2.3.1.1 General In this Standard, housing is defined as Class 1 buildings and Class 10 buildings, as described in the Building Code of Australia, and is governed by the limitations specified in AS4055, except that windows in Class 10 buildings are not required to pass the air infiltration and water penetration requirements of this Standard.”

AS4055-1992 Wind loads for housing, Clause 6, Limitations

- The distance from ground level to the underside of eaves shall not exceed 6.0 m; from ground level to the highest point of the roof, neglecting chimneys, shall not exceed 8.5 m; and the height of each storey at external walls shall not exceed 2.7 m
- The width (W), including roofed verandahs but excluding eaves, shall not exceed 16.0 m, and the length (L) shall not exceed five times the width.
- The roof pitch shall not exceed 35°.

Residential buildings: AS2047-1999 Clause 2.3.2.1 “...covers residential buildings of Class 2, Class 3 and Class 4 parts of buildings as described in the Building Code of Australia, and Class 1 buildings outside the limitations specified in AS4055.”

Commercial buildings: AS2047-1999 Clause 2.3.3.1 “...covers commercial buildings of Classes 5, 6, 7, 8 and 9 as described in the Building Code of Australia.”

Ratio of Ultimate (P_u) to Serviceability (P_s) Limit State Pressures : Ratios of $\left(\frac{V_u}{V_s}\right)^2$ using Regional wind speeds from AS1170.2-1993, Figure 3.2.2, table “BASIC WIND SPEEDS IN DIFFERENT REGIONS” are:
Region A: $P_u = 1.73xP_s$, Regions B & C: $P_u=2.5xP_s$ & Region D: $P_u=2.9xP_s$.

1 Preparation for Tests: AS4420.1-1996

Test Description

Prior to commencement of the main tests listed below, any operable windows or doors are to be opened and close five (5) times. The sample is to be subject to positive or negative wind pressures being 50% of the nominated deflection test pressures. This is a pre-requirement for each of the main tests. However, when more than one of the tests is to be conducted the preparations need only be conducted once.

2 Deflection Test : AS4420.2-1996

Test Description

Measurements of movement of critical structural members are taken at a range of test pressures in order to determine if the bending of the members exceed the nominated requirements.

Test Parameters

Test Pressure: is dependent on the type of building nominated by the client-

Housing: Based on Window Rating nominated by client as given in the following table:

Window Rating	Test Pressure (Pa)
N1	500
N2	700
N3	1000
N4	1500
N5	2200
N6	3000

Residential or Commercial Buildings:

The pressure shall be the Serviceability Limit State Pressure.

Deflection Test (continued)

Test pressure steps: as given below

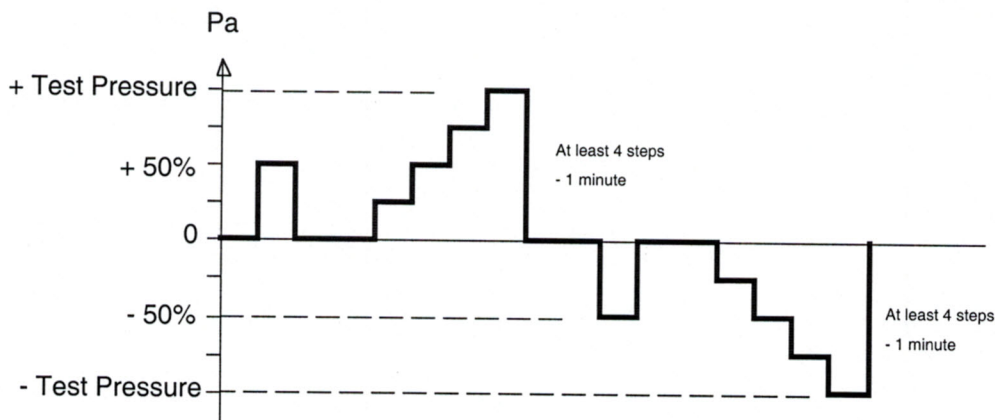

Pass / Fail criteria:

Maximum deflection for structural members is dependent on the type of building-

Housing:	1/150 of span.
Residential buildings:	1/180 of span @ Serviceability Limit.
Commercial buildings:	1/250 of span @ Serviceability Limit.

3 Operating Force Test : AS4420.3-1996

Test Description

The forces required to operate sliding doors and windows are measured to test compliance with the requirements.

Test Parameters

Test measurements: The forces required to initiate and sustain movement of the door/sash in both directions of movement are recorded.

Pass / Fail criteria : Forces shall not exceed the following

Force (Newtons)	Sliding window type		Sliding doors
	Horizontal	Vertical	
To initiate movement	110	200	180
To sustain movement	90	160	110

4 Air Infiltration Test: AS4420.4-1996

Test Description

Air leakage through the entire test sample is measured at the nominated pressures in order to determine if it exceeds the allowable rate.

Test Parameters

Pass / Fail criteria : Maximum air infiltration shall not exceed either of the following

Building type or window type	Pressure direction	Maximum air infiltration, L/s.m ²	
		@75 Pa	@150 Pa
Airconditioned	Positive, negative	1.0	1.6
Non-airconditioned	Positive	5.0	8.0
Louvre window	Positive	20.0	Not applicable
Adjustable louvres, residential and commercial buildings	Positive	20.0	32.0

Test Description

Water is sprayed onto the outdoor face of the test sample with air pressure simultaneously being applied across it to determine if unacceptable water leakage occurs.

Test Parameters

Test pressure : The test pressure is dependent on the type of building-

Housing: Based on Window Rating nominated by client as given in the following table-

Window ratings	Water penetration resistance test pressure (Pa)	
	All windows except adjustable louvres	Adjustable louvre windows
N1	150	150
N2	150	150
N3, C1	150	150
N4, C2	200	200
N5, C3	300	200
N6, C4	450	200

Residential or Commercial Buildings:

The test pressure shall be 30% of Serviceability Limit State Pressure but not less than 150 Pa.

Test duration: The test pressure shall be maintained for 15 minutes.

Water application rate : 0.05 litre per second per square metre of sample area.

Pass / Fail criteria :

“Windows for Class 1 buildings shall be subjected to the water penetration resistance test in accordance with AS 4420.5, under the test pressures specified in Table 2.4. During and at the completion of the test there shall have been no penetration of uncontrolled water. Uncontrolled water is defined as-

- (a) water that is not contained in a purpose-built drainage area;
- (b) water that wets or is likely to wet insulation, fixtures and finishes, reveal linings or window furnishings beyond the window frame; or
- (c) water that lies on transoms, rails, sills, etc., that has no designed means of escape to the outside of the product via the drainage system.

Acceptable water penetration is not deemed a failure if-

- (i) minor splashing occurs due to air infiltration, within 1 mm after change of pressure;
- (ii) minor, intermittent leakage on the indoor side of openable sashes, which is contained on sash gaskets, sill tracks and thresholds that are part of a drainage system that allows water to flow to the outside of the product at cessation of the test (constant streams and regular dripping would be regarded as failure); or
- (iii) water running down the indoor face of louvers, which is completely contained within a purpose-built drainage area.

Test Description

Air pressure greater than the design pressure is applied across the test sample in order to demonstrate that it has a suitable structural safety margin.

Test Parameters

Test Pressure: is dependent on the type of building nominated by the client-

Housing: Based on Window Rating nominated by client as given in the following table-

Window Rating	Test Pressure (Pa)
N1	700
N2	1000
N3	1500
N4	2300
N5	3300
N6	4500

Residential or Commercial Buildings: the pressure shall be the Ultimate Limit State Pressure .

Pass / Fail criteria:

Windows shall not collapse when subjected to the test pressures for a period of ten (10) seconds. Collapse is defined as any one, or any combination, of the following:

- (a) Failure or dislodgment of any glazing.
- (b) Dislodgment of a frame or any part of a frame.
- (c) Removal of a light, either with or without its framing sash, from a frame.
- (d) Loss of support of a frame, such as when it is unstable in its opening in the building structure.
- (e) Failure of any sash, locking device, fastener or supporting stay allowing an opening light to open.

Retesting (if required)

Clause 7 of AS4420.1 states:

“If the test sample requires modification to gaskets, joints seals or drainage details to enable it to pass either the air infiltration test or the water penetration resistance test, then both tests shall be repeated in full. Before retesting, the test sample shall be checked for being operative (see Clause 4.1) and the deflection pressures, both positive and negative, shall be applied for 1 min each to the test sample. Any modifications to the test sample shall be noted in the respective drawing and the amendment coded thereon.”

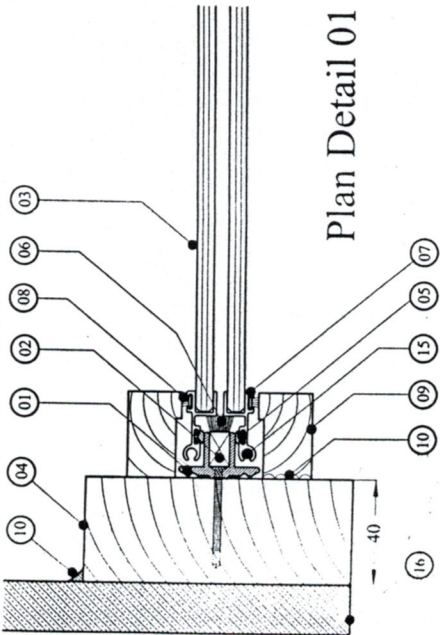

Plan Detail 01

- 01 PVC Runner - Fixing Screws, 8g x 55 @ 350 Centres
- 02 19mm SS Pulley at Top
- 03 6mm Toughened Glass
- 04 Outer Timber Window Frame 135mm x 40mm (Fully sealed joints)
- 05 Schlegal Inner Seal, PB 48500-3P
- 06 Mohair Draft Excluder, 25mm Long on PVC Block at Overlap
- 07 Aluminium Sash Stiles (EA. 2145). Silicone Sealed
- 08 Schlegal Fin Seal. TSF 4860
- 09 WRC Inner and Outer Guide, 32mm x 19mm, Gal Nails at 400 Centres
- 10 Silicone Seal
- 11 Head Seal. WRC 32mm x 19mm
- 12 Sill Seal. WRC 32mm x 19mm
- 13 Schlegal Sill & Head Woolpile, TSF 4875
- 14 Acrylic Blocks 100mm x 10mm, Siliconed to Glass
- 15 3mm Spectra Chord
- 16 400mm x 19mm MDF Reveal
- 17 Clear PVC Seal with Schlegal PBF 48525 Woolpile
- 18 12mm x 3mm Closed Cell Foam Tape
- 19 Timber Window Sill WRC 165mm x 40mm.
- 20 Window Lock

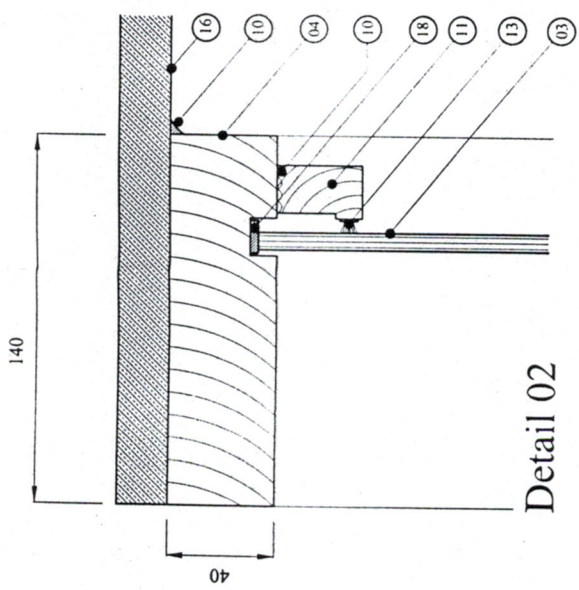
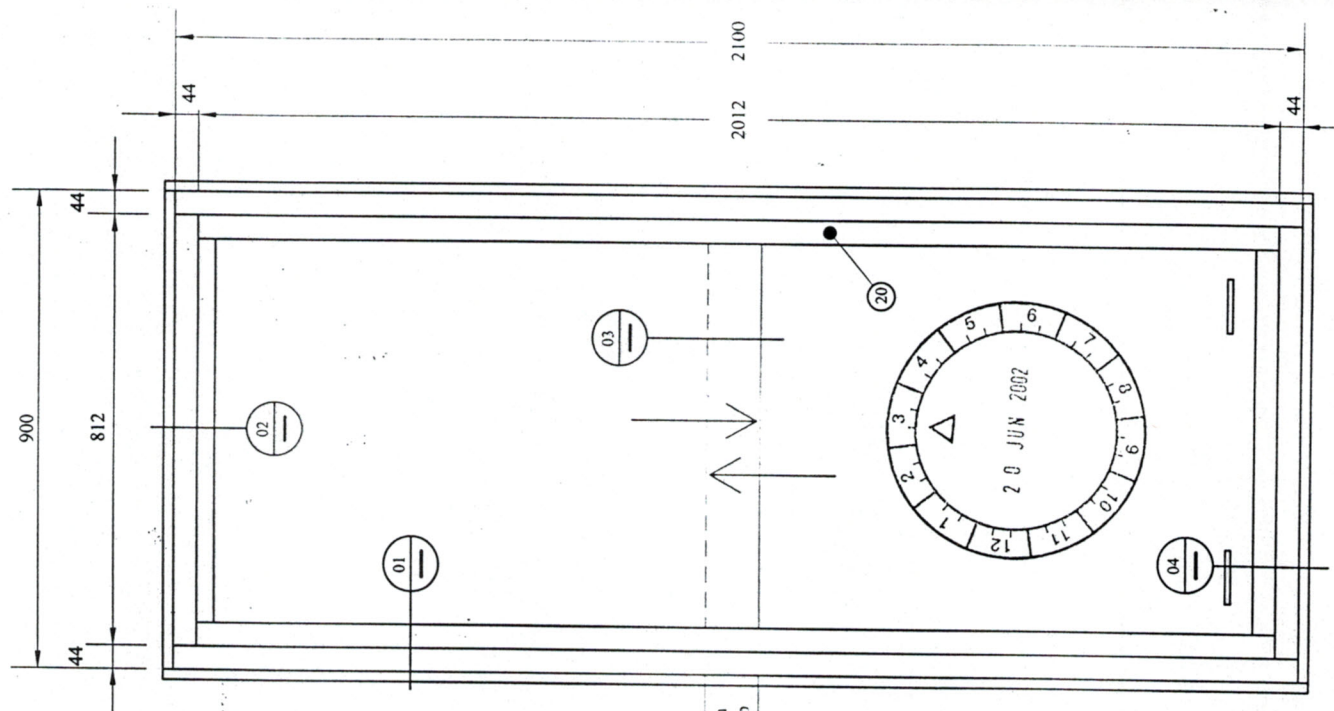

Detail 02

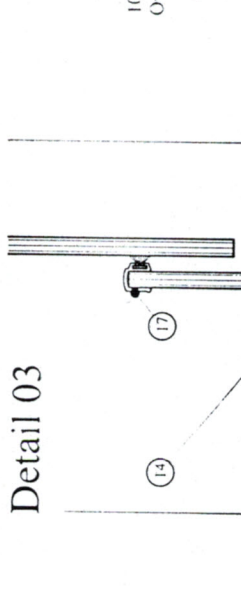

Detail 03

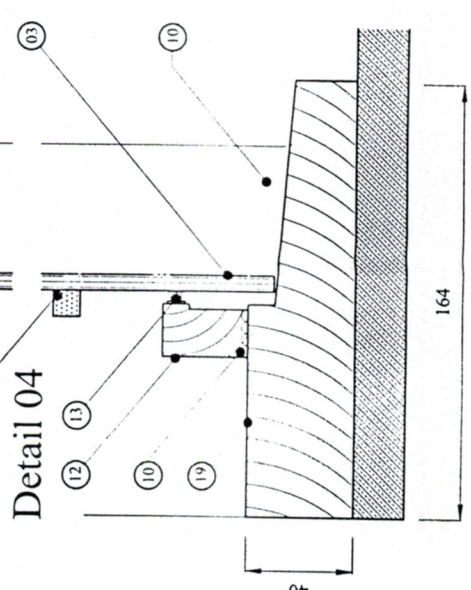

Detail 04

Timber Sashless Double Hung Window
Inset into Timber Window Frame

Drawn SSD
Checked
Scale 1:2 - 1:10

DATE April 2002

Sample Test Details

Dwg TD-02



Sashless Windows
38-40 Howard Street, North Melbourne. 3051
Ph: (03) 9326 9944 Fax: (03) 9326 3144
Website: austview.com.au