

IAN BENNIE AND ASSOCIATES

TEST REPORT NO. 20324S2

**SASHLESS DOUBLE HUNG, DOUBLE
GLAZED WINDOW IN TIMBER FRAME
PROTOTYPE TEST to AS2047-1999**

for

Austview Sashless Windows

May 2004



Registered Laboratory No. 2371



IAN BENNIE & ASSOCIATES PTY. LTD.
Building Performance Testing

ACN : 007 133 253



Registered
 Laboratory
 No. 2371

WINDOW TEST NUMBER 20324S2

Test Client: Austview Sashless Windows

Sample

Identification: A Sashless Double Hung, Double Glazed Window in Timber Frame, measuring, 2100 mm in height x 900 mm in width. The sample is detailed in the Austview Sashless Windows drawing given in Appendix C.

Test Method: Operating Force, Air Infiltration, Water Penetration Resistance and Ultimate Strength test performance requirements to Clause 2.3 of Australian Standard AS2047-1999, and test procedures to Australian Standard AS4420-1996 as detailed in Appendix A.

Test Location: IBA Test Centre
 Dandenong, Melbourne.

Test Date(s): 26 February 2004.

Drawing(s) Received: 26 February 2004

Pre-loading: The sample was operated five (5) times prior to commencement of testing.

TEST RESULTS

Deflection Test

Not required as the sample did not contain any structural framing members.

Operating Force Test

Force (Newton)	Requirement	Force Measured
To initiate movement	200 maximum	Opening: 149 Closing : 154
To maintain movement	160 maximum	Opening: 146 Closing : 141

Air Infiltration Test

Air Leakage Recorded (L/s.m ²)	Pressure Applied (Pa)			
	+75	+150	-75	-150
Condition				
Chamber & Sample (A):	1.80	2.58	-2.00	-3.20
Chamber (sample taped) (B):	NR	NR	NR	NR
Sample (A-B):	1.80	2.58	-2.00	-3.20

NR: measurement not required

Water Penetration Test, 200 Pa

No water penetration was observed during the test.

Water Penetration Test, 250 Pa

Water was observed in two locations during the test.

- 1/ Water penetrated up past the right end of the meeting rail and drops sprayed over the back of glass. This water constitutes a failure.
- 2/ Water penetrated up past the left end of the meeting rail and drops sprayed over the back of glass. This water constitutes a failure.

Ultimate Strength Test: +2300 Pa & -2300 Pa

No sign of collapse was observed at either test pressure.

CONCLUSION

The Sashless Double Hung, Double Glazed Window in Timber Frame sample achieved the following ratings per AS2047-1999 and Building Importance Level 2 when tested for Operating Force, Air Infiltration, Water Penetration Resistance and Ultimate Strength. Referenced Standards, building classifications, housing limitations and Region data are summarised in Appendix B.

NOTES:

1. Ratings have been calculated using the 2002 issue of AS/NZS 1170.2. The client can re-calculate the ratings using the 1989 issues of AS 1170.2 from the test results if required.
2. Ratings have only been calculated for BCA Building Importance Level 2. The client can re-calculate the ratings for other levels of importance from the test results if required.

Housing ratings:

Regions A & B N4 #[‡]
Region C +670 ‡ and -980 # Pa
Region D +670 ‡ and -770 # Pa

Residential and Commercial building ratings:

Region A +670 ‡ and -1550 # Pa
Region B +670 ‡ and -1020 # Pa
Region C +670 ‡ and -980 # Pa
Region D +670 ‡ and -770 # Pa

‡ - rating is limited by the maximum water test pressure applied without failure.

- rating is limited by the maximum ultimate test pressures applied without failure.

Air Infiltration: Non-airconditioned Buildings ONLY

Maximum Water Penetration Resistance Pressure: 200 Pa

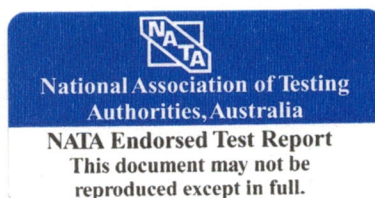

DISTRIBUTION:

Ian Bennie & Associates 3
Austview Sashless Windows 2

.....
Derek Dubout 11 May 2004
Authorised NATA Signatory

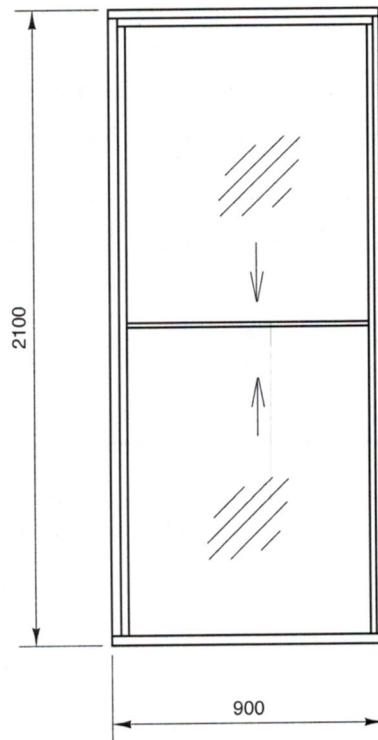

INDOOR VIEW

Figure 1. Indoor view of the test sample.

3 Operating Force Test : AS4420.3-1996

Test Description

The forces required to operate sliding doors and windows are measured to test compliance with the requirements.

Test Parameters

Test measurements: The forces required to initiate and sustain movement of the door/sash in both directions of movement are recorded.

Pass / Fail criteria : Forces shall not exceed the following

Force (Newtons)	Sliding window type		Sliding doors
	Horizontal	Vertical	
To initiate movement	110	200	180
To sustain movement	90	160	110

4 Air Infiltration Test: AS4420.4-1996

Test Description

Air leakage through the entire test sample is measured at the nominated pressures in order to determine if it exceeds the allowable rate.

Test Parameters

Pass / Fail criteria : Maximum air infiltration shall not exceed either of the following

Building type or window type	Pressure direction	Maximum air infiltration, L/s.m ²	
		@75 Pa	@150 Pa
Airconditioned	Positive, negative	1.0	1.6
Non-airconditioned	Positive	5.0	8.0
Louvre window	Positive	20.0	Not applicable
Adjustable louvres, residential and commercial buildings	Positive	20.0	32.0

5 Water Penetration Resistance Test AS4420.5-1996

Test Description

Water is sprayed onto the outdoor face of the test sample with air pressure simultaneously being applied across it to determine if unacceptable water leakage occurs.

Test Parameters

Test pressure : The test pressure is dependent on the type of building-

Housing: Based on Window Rating nominated by client as given in the following table-

Window ratings	Water penetration resistance test pressure (Pa)	
	All windows except adjustable louvres	Adjustable louvre windows
N1	150	150
N2	150	150
N3, C1	150	150
N4, C2	200	200
N5, C3	300	200
N6, C4	450	200

Residential or Commercial Buildings:

The test pressure shall be 30% of Serviceability Limit State Pressure but not less than 150 Pa.

5 Water Penetration Resistance Test AS4420.5-1996 (continued)

Test duration: The test pressure shall be maintained for 15 minutes.

Water application rate : 0.05 litre per second per square metre of sample area.

Pass / Fail criteria :

“Windows for Class 1 buildings shall be subjected to the water penetration resistance test in accordance with AS 4420.5, under the test pressures specified in Table 2.4. During and at the completion of the test there shall have been no penetration of uncontrolled water. Uncontrolled water is defined as-

- (a) water that is not contained in a purpose-built drainage area;
- (b) water that wets or is likely to wet insulation, fixtures and finishes, reveal linings or window furnishings beyond the window frame; or
- (c) water that lies on transoms, rails, sills, etc., that has no designed means of escape to the outside of the product via the drainage system.

Acceptable water penetration is not deemed a failure if-

- (i) minor splashing occurs due to air infiltration, within 1 mm after change of pressure;
- (ii) minor, intermittent leakage on the indoor side of openable sashes, which is contained on sash gaskets, sill tracks and thresholds that are part of a drainage system that allows water to flow to the outside of the product at cessation of the test (constant streams and regular dripping would be regarded as failure); or
- (iii) water running down the indoor face of louvers, which is completely contained within a purpose-built drainage area.

6 Ultimate Strength Test AS4420.6-1996

Test Description

Air pressure greater than the design pressure is applied across the test sample in order to demonstrate that it has a suitable structural safety margin.

Test Parameters

Test Pressure: is dependent on the type of building nominated by the client-

Housing: Based on Window Rating nominated by client as given in the following table-

Window Rating	Test Pressure (Pa)
N1	700
N2	1000
N3	1500
N4	2300
N5	3300
N6	4500

Residential or Commercial Buildings: the pressure shall be the Ultimate Limit State Pressure .

Pass / Fail criteria:

Windows shall not collapse when subjected to the test pressures for a period of ten (10) seconds. Collapse is defined as any one, or any combination, of the following:

- (a) Failure or dislodgment of any glazing.
- (b) Dislodgment of a frame or any part of a frame.
- (c) Removal of a light, either with or without its framing sash, from a frame.
- (d) Loss of support of a frame, such as when it is unstable in its opening in the building structure.
- (e) Failure of any sash, locking device, fastener or supporting stay allowing an opening light to open.

Retesting (if required)

Clause 7 of AS4420.1 states:

“If the test sample requires modification to gaskets, joints seals or drainage details to enable it to pass either the air infiltration test or the water penetration resistance test, then both tests shall be repeated in full. Before retesting, the test sample shall be checked for being operative (see Clause 4.1) and the deflection pressures, both positive and negative, shall be applied for 1 min each to the test sample. Any modifications to the test sample shall be noted in the respective drawing and the amendment coded thereon.”

APPENDIX B – Guide to Interpretation of Results and References

This appendix provides information extracted from the relevant Australian Standards and Codes to aid in understanding the method for determining a Rating of a test sample.

Standards and Codes used

AS 2047:1999 – Windows in buildings, including Amendments 1 and 2.

AS 4420:1996 – Windows-Methods of test, Parts 0 to 5

AS 4055:1992 – Wind loads for housing, including Amendment 1

AS/NZS 1170 - Structural design actions

1170.0:2002 - General principles

1170.0 Supplement 1:2002 - Commentary

1170.2:2002 - Wind Actions

1170.2 Supplement 1:2002 – Commentary

Building Code of Australia, including Amendment 11: July 2002

Building Classifications

Housing

AS2047 Clause 2.3.1.1 *General* In this Standard, housing is defined as Class 1 buildings and Class 10 buildings, as described in the Building Code of Australia, and is governed by the limitations specified in AS4055, except that windows in Class 10 buildings are not required to pass the air infiltration and water penetration requirements of this Standard.”

AS4055 Clause 6, Limitations

- (a) The distance from ground level to the underside of eaves shall not exceed 6.0 m; from ground level to the highest point of the roof, neglecting chimneys, shall not exceed 8.5 m; and the height of each storey at external walls shall not exceed 2.7 m
- (b) The width (W), including roofed verandahs but excluding eaves, shall not exceed 16.0 m, and the length (L) shall not exceed five times the width.
- (c) The roof pitch shall not exceed 35°.

Residential buildings

AS2047 Clause 2.3.2.1 “...covers residential buildings of Class 2, Class 3 and Class 4 parts of buildings as described in the Building Code of Australia, and Class 1 buildings outside the limitations specified in AS4055.”

Commercial buildings

AS2047 Clause 2.3.3.1 “...covers commercial buildings of Classes 5, 6, 7, 8 and 9 as described in the Building Code of Australia.”

Design Wind Speeds

In a change from the previous issue of AS1170.2, the 2002 issue replaced predefined Basic Regional Wind Speeds for Serviceability, Permissible and Ultimate design with Regional Wind Speeds in terms of average annual recurrence intervals (R) (refer Section 3.1). Determination of the appropriate annual recurrence intervals for Serviceability, Permissible and Ultimate design is now specified in other Standards and Codes as follows:

Serviceability Limit State

Guidance is given in AS/NZS 1170.0 General Principles, which identifies a recurrence interval of 20 years as appropriate for serviceability limit state. (refer to Appendix C of the Standard).

Permissible Stress

Permissible Stress is all but removed from the 2002 issues of the structural design Standards. Clause C3.2 of AS/NZS 1170.2 Supplement states "The permissible stress gust wind speed may be obtained by dividing the wind speed given in the Standard by the square root of 1.5".

Ultimate Limit State

AS1170.0 nominates that the Building Code of Australia (BCA) is used in Australia to determine the recurrence intervals for Ultimate Strength based on a building's Importance Factor. These are indicated in the table below. Refer to the BCA for definitions of importance. For New Zealand, AS/NZS 1170.0 determines the annual recurrence intervals based on Importance Levels and Design Working Life of buildings (refer to Section 3 of the Standard).

Building Importance Levels for Ultimate Strength Wind Loads

This table is defined in the BCA for Australia and AS/NZS1170.2 for New Zealand

Building Importance Level	Recurrence Interval (years)
1 Non-cyclonic	100
1 Cyclonic	200
2	500
3	1000
4	2000

Regional Wind Speeds per AS1170.2

Recurrence Interval (years)	Design State	Regional Wind Speeds				
		Regions				
		A (1 to 7)	W	B	C ¹	D ¹
20	Serviceability, $V_{s,20}$	37	43	38	45	51
100	Ultimate, $V_{u,1NC}$	41	47	48	-	-
200	Ultimate, $V_{u,1C}$	-	-	-	64	80
500	Ultimate, $V_{u,2}$	45	51	57	69	88
1000	Ultimate, $V_{u,3}$	46	53	60	73	93
2000	Ultimate, $V_{u,4}$	48	54	63	77	99

Notes:

1. Values of FC = 1.05 and FD = 1.10 have been applied to the Ultimate Wind Speeds in Regions C & D respectively.
2. For New Zealand, a building Design Working Life of 50 years has been applied.

Calculated Ratio of Design Wind Loads and Window Ratings

Ratio of Ultimate and Serviceability Wind Loads

As a result of the changes in AS1170.2 and other codes as detailed in the previous section in this Appendix, there are now no less than 20 possible ratios of Ultimate and Serviceability Wind Speeds depending on Region and Building Importance.

In order to determine the Rating of a generic window sample tested in accordance with AS2047, it is necessary to apply the ratio of Ultimate and Serviceability **WIND LOADS** for all building types other than Housing in regions A and B.

The following table calculates the Wind Load Ratio p_U / p_S which is equal to $(V_U / V_S)^2$, NOT the ratio of wind speeds. The Wind Load Ratio enables determination of Serviceability Wind Loads from the Ultimate Wind Loads applied during testing.

Wind Load Ratio

Building Importance Level	Ultimate Recurrence Interval (yrs)	Wind Load Ratio (p_U / p_S)				
		Regions				
		A (1 to 7)	W	B	C	D
1 Non-cyclonic	100	1.23	1.19	1.60	-	-
1 Cyclonic	200	-	-	-	2.02	2.46
2	500	1.48	1.41	2.25	2.35	2.98
3	1000	1.55	1.52	2.49	2.63	3.33
4	2000	1.68	1.58	2.75	2.93	3.77

Calculation of Window Rating

In calculating the Window Ratings provided in the conclusion of this report, Ian Bennie and Associates apply the following procedure.

For Housing in regions A & B the results of the Deflection, Water Penetration and Ultimate Tests are checked against the values specified in AS2047 and the lowest rating achieved in the individual tests is reported as the Window Rating.

For Housing in Regions C & D, Residential and Commercial buildings the resultant serviceability wind loads (RSWLs) are first calculated for each of the three wind pressure dependent tests (Deflection, Water Penetration and Ultimate). The lowest positive and negative RSWLs are reported as the Window Rating. RSWLs are calculated for each of the tests as follows:

Deflection Test: The RSWL is the largest positive and negative pressures applied during the test where the deflection of all framing members was less than that required for the different building classifications.

Water Penetration Test: The RSWL is the largest pressure applied during the test without failure divided by 0.3. The pressure value is divided by 0.3 as the Standards requires the water test pressure to be 30% of the Serviceability Pressure.

Ultimate Test: The RSWL is the largest pressure applied during the test without failure divided by the Wind Load Ratios calculated for Importance Level 2 in the table above. An Importance Level of 2 has been used as it is by far the most common type of building. There is no reason why Ratings for other Importance Levels can not be calculated from the test data.

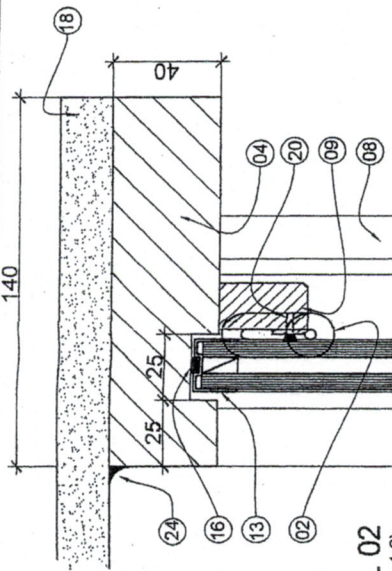
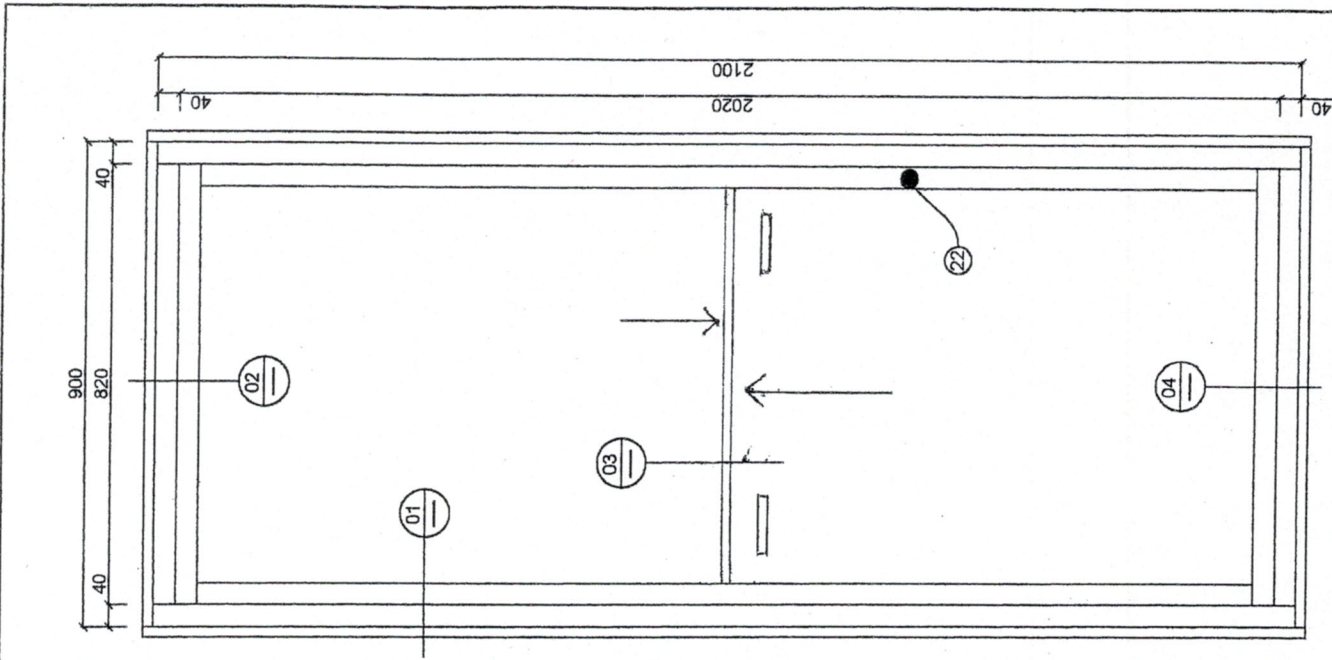

DETAIL 02
(Scale 1:2)

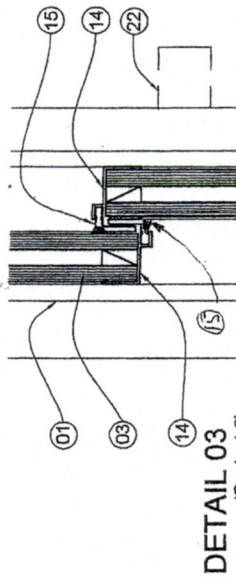

DETAIL 03
(Scale 1:2)

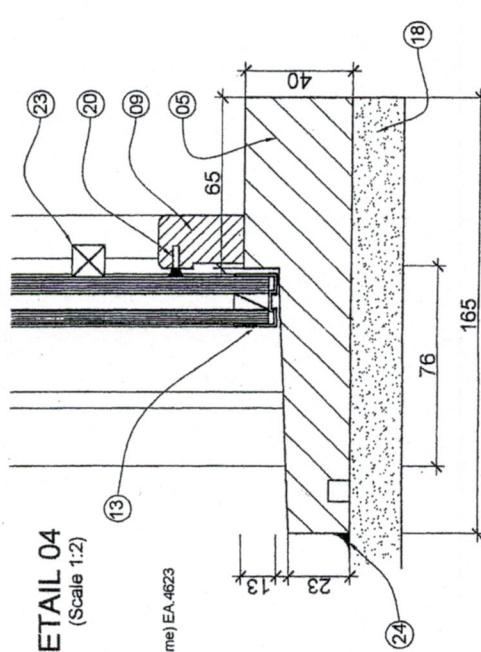

DETAIL 04
(Scale 1:2)

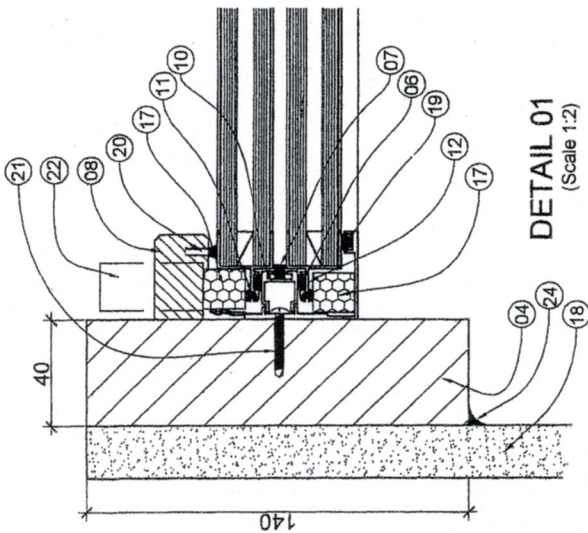

DETAIL 01
(Scale 1:2)

LEGEND

- 01 Aluminium jamb (includes: Outer guide, screw fixed @450ccts and sealed to outer frame) EA-4623
- 02 Stainless steel pulley at top centre
- 03 18mm thick double glazed unit 4mm Tuffr10 air/4mm Tuff
- 04 Outer WRC frame 140x40 head and jamb (fully sealed)
- 05 Sill merbu 165x40
- 06 Schlegal inner seal PBA46500-3P
- 07 Mohair draft excluder 50mm at overlap
- 08 Internal WRC guide 32x19
- 09 WRC head and sill 32x19
- 10 Centre bead aluminium EA-4620 holding item no.7
- 11 3mm spectra chord
- 12 Aluminium sash sillies 12mm cover siliconed to glass EA-4622
- 13 Aluminium rail to top and bottom of glass 12mm cover siliconed to glass EA-4625
- 14 Aluminium interlock 12mm cover siliconed to glass EA-4621
- 15 Woodpile seal to inside interlock rail, schlegal PS11
- 16 Q-lon seal to head, Schlegal QEZ48
- 17 Closed cell foam 40x15x15mm draft excluder blocks to inner and outer covers and sash sillies at overlap
- 18 Schlegal fin seal PBF-4960 to inner guide no.7
- 19 Schlegal seal TSF-4850 to WRC guide no.8
- 20 Fixing screw @450ccts
- 21 Key lock at overlap
- 22 Acrylic lifts bonded with silicone to glass
- 23 Silicone seal



38-40 Howard Street,
North Melbourne, 3050.
Phone: (03) 9326 9944
Fax: (03) 9326 3144

23 Bullivant Street,
Warragatta 3677.
Phone: (03) 5721 2788
Fax: (03) 5721 9519

Date: November 2003
Drawn: SH
Dwg #: AV1103

Double Glazed counter balanced
Window fixed to Timber frame

Drawing: Head, Sill, Jamb and
Transom Details

Scale 1:2 - 1:10

Page: 1 of 1