

HEAD, SILL AND JAMB

Head Detail

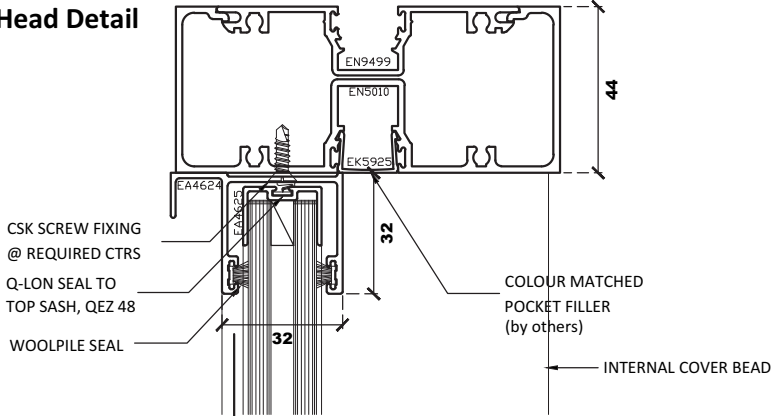

Interlock Detail

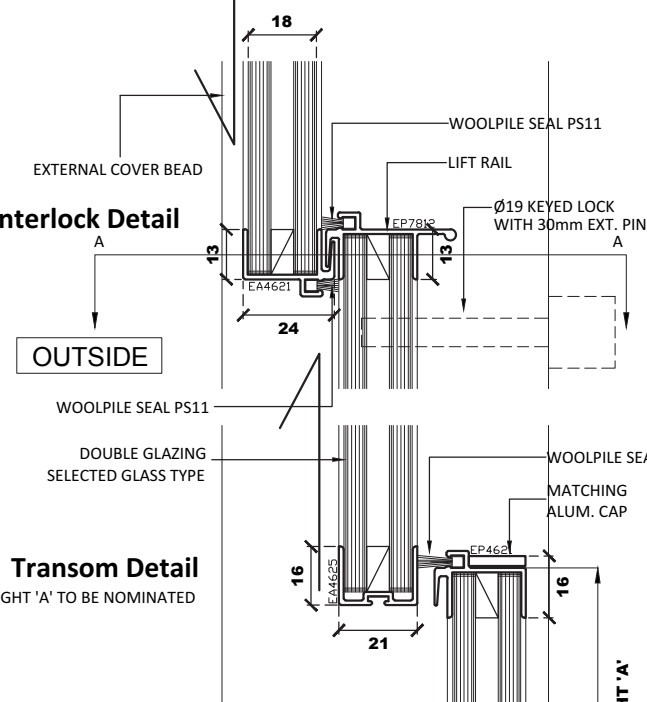

Transom Detail

NOTE: HEIGHT 'A' TO BE NOMINATED

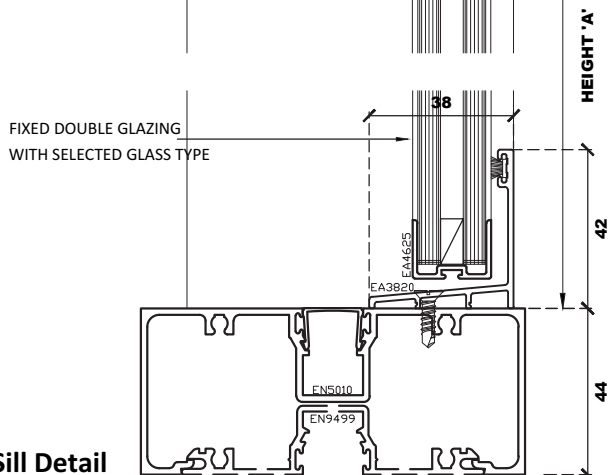

Sill Detail



Jamb Detail A

